

Wall Mounted Luminaire Installation Instructions

General Installation

WARNING

TO REDUCE RISK OF DEATH, INJURY OR PROPERTY DAMAGE FROM FIRE, ELECTRIC SHOCK AND OTHER HAZARDS:

The service of equipment must be performed by qualified personnel.

Installation and maintenance must be performed by qualified personnel familiar with the construction and operation of this product and any hazards involved. All applicable local, state and federal codes and ordinances must be followed.

Read this document before installing, servicing, or maintaining this equipment. These instructions do not cover all installation, service, and maintenance situations. If your situation is not covered, or, if you do not understand these instructions or need additional information, contact Lumato or your local Lumato distributor.

WARNING

BEFORE INSTALLING, SERVICING OR MAINTAINING THIS EQUIPMENT, FOLLOW THESE GENERAL PRECAUTIONS TO REDUCE THE RISK OF ELECTROCUTION:

Make sure the equipment is properly grounded.

Always de-energize the circuit and/or equipment before connecting to, disconnecting from or servicing the equipment.

TO PREVENT LUMINAIRE ROW FROM OVER-CURRENT:

By adding the input current of each luminaire section marked on the luminaire, the total current per power feed must not exceed the maximum line wire amperage rating in the luminaire and the power feed cord/wire amperage rating whichever is least.

WARNING

IT IS THE INSTALLERS RESPONSIBILITY TO ENSURE THAT WALL, CEILING OR JUNCTION BOX IS STRUCTURALLY CAPABLE OF SUPPORTING THE WEIGHT OF LUMINAIRE/LUMINAIRE ROW.

NOTE: The fixture markings can be found on labels positioned behind the direct lens. To access these labels, carefully pry off the direct lens from one end of the fixture using a flat tool or plastic card.

2W DIRECT

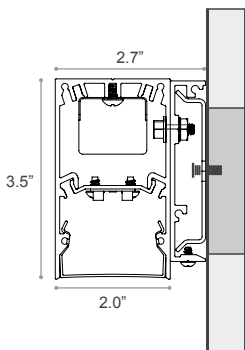

3W DIRECT

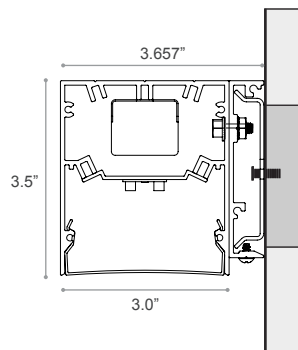

2WID INDIRECT/DIRECT

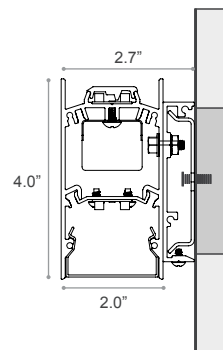

3WID INDIRECT/DIRECT

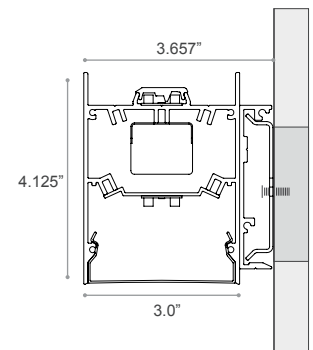

SAVE THESE INSTALLATION INSTRUCTIONS

Wall Mounted Luminaire Installation Instructions

Individual Mounting

INDIVIDUAL LUMINAIRE INSTALLATION:

Wall Mounting: Linear luminaires intended for “Wall Mounting” mounting cleats are to be installed with appropriate anchors “by others”. Mounting cleats are shipped with the product and should be installed in accordance with these instructions and with local, state, and federal regulations.

Step One: Remove the lens and LED/Reflector Tray and store safely aside. Using wall cleat supplied with luminaire as a template, center over horizontally mounted switch box, use a level to ensure that the wall cleat is plumb (horizontally aligned), and mark the locations for the two mounting holes. (FIG. 1) Drill appropriate holes for mounting surface and fasteners to be used. Securely attached wall cleat to the wall.

Step Two: Attach additional wall cleat(s) supplied to the mounting surface at the location(s) as specified at the end of this document. Ensure that all wall cleats are plumb and on the same centerline as the first one installed. All wall cleats should be centered over every set screw in luminaire housing. Remove the lens and the reflector to access wiring compartment.

Figure 1

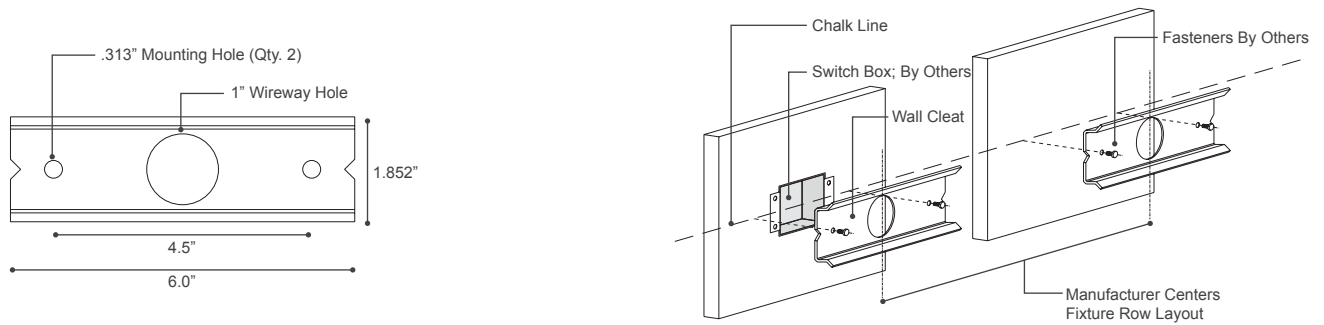

Step Three: To install the luminaire onto the wall bracket rails, follow these steps:

1. Hold the luminaire at a slight angle with the bottom of the unit away from the wall and the top of the unit against the wall.
2. Lower the top lip of the wall bracket rails over the top lip of the wall cleat, ensuring a secure fit.
3. Carefully run the supply leads through the wire feed hole, taking care to avoid any pinching of the wire leads.
4. Gradually lower the unit into its final position on the wall.
5. Install the set screws provided and tighten them enough to firmly hold the luminaire in place against the wall. Refer to FIG. 2 for visual guidance.

Note: It is important not to over tighten the set screws, as they should only be tightened sufficiently to secure the luminaire to the wall.

Step Four: Connect incoming supply wire leads to luminaire wire leads using 90°C minimum rated supply wires and connectors.

Step Five: Reassemble LED/Reflector tray in reverse fashion and ensure that there are no wires bound by the reflector as this will cause the lens to not fit correctly. For 2” wide product line only: When reinstalling the LED tray, hold it firm in the housing tracks, screw the first #8-18x1/4” screw with just a few revolutions, move to the middle, and to the last screw before screwing the first screw all the way in. Not following this step will cause the LED Tray to slide out of position and interfere with the end cap or the next fixture in a row.

Power up the row and reinstall the lens.

Figure 2

View is From Wall for Illustrative Purposes

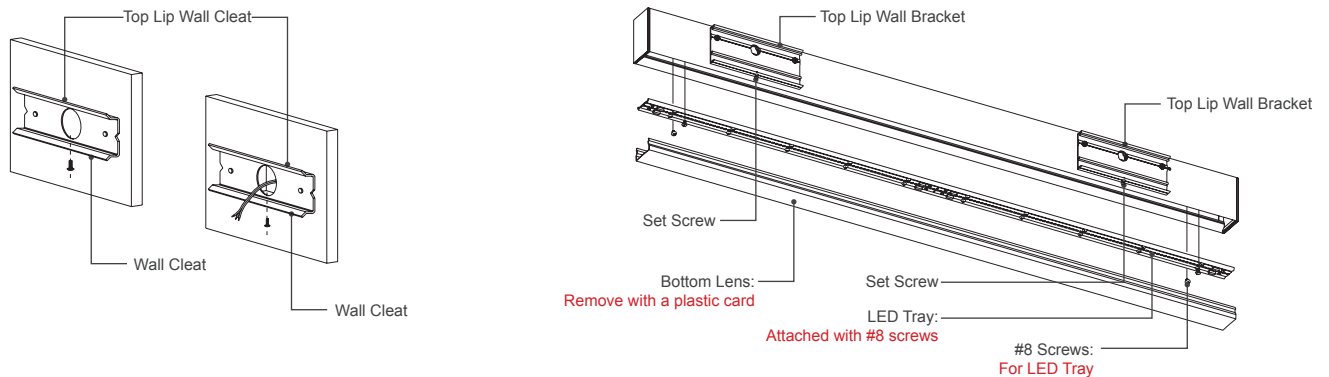

SAVE THESE INSTALLATION INSTRUCTIONS

Wall Mounted Luminaire Installation Instructions

Row Mounting

CONTINUOUS LUMINAIRE INSTALLATION:

WARNING

IT IS THE INSTALLERS RESPONSIBILITY TO ENSURE THAT WALL, CEILING OR JUNCTION BOX IS STRUCTURALLY CAPABLE OF SUPPORTING THE WEIGHT OF LUMINAIRE/LUMINAIRE ROW.

Step One: From centerline of horizontally mounted switch box(es), snap a horizontal chalk line on the wall to the right of J-box approximately the full length of luminaire row mounting centers.

Step Two: Attach wall cleats as instructed on the previous page and on centers as specified at the end of this document using chalkline. (FIG. 3)

Step Three: Remove the Bottom lens and LED/Reflector tray(s) from fixtures and store in order of run placement storing safely aside (FIG. 4). It is best to perform the following tasks on a protective, elevated, stable surface to ease assembly and protect the fixtures.

Step Four: Locate Joiner Kits (FIG. 3B). See the packing list for quantities per run.

Attach the Joiner Bracket with two #10 screws positioning it so that the Center Tension Screw is located 1/16" from the edge of the housing (towards the middle of the fixture). Joining fixtures should mate easily leaving no gaps between housings.

Repeat this process for the balance of the fixtures in the run as needed. Complete each fixture in the run to assure the run can be assembled from left to right as intended.

Figure 3

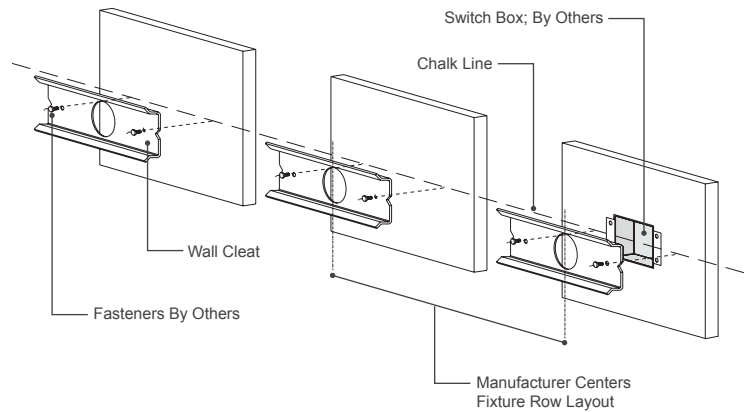

Figure 3A

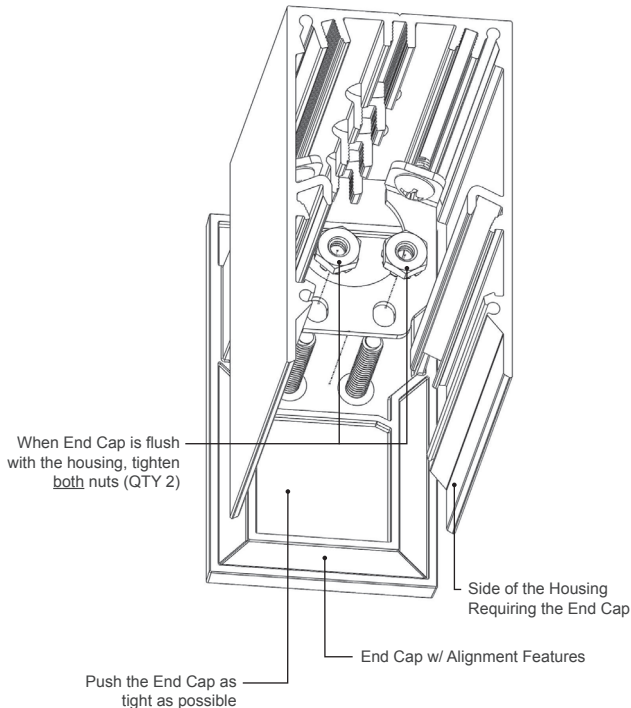
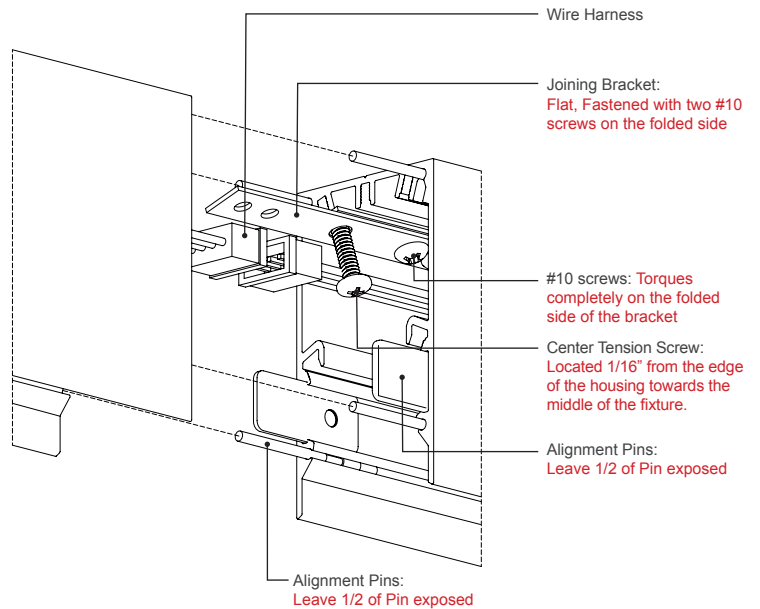

Figure 3B



SAVE THESE INSTALLATION INSTRUCTIONS

Wall Mounted Luminaire Installation Instructions

Row Mounting

Step Five: Lower the top lip of wall bracket rails over the top lip of wall cleat by holding luminaire at a slight angle with the bottom of the unit away from the wall and the top of the unit at the wall. Run supply leads through wire feed hole ensuring that the wire leads are not being pinched, lower unit down into position. Install set screws and tighten only enough to hold luminaire tight to the wall. (FIG.4) Position second fixture in a row (JOINER/INTERMEDIATE) such that it aligns with the joint end of the first fixture as illustrated.

Step Six: Plug luminaire wire harness together and push the excess wire back into wireway. Push luminaires tightly together while making sure the alignment pins slide into the interior tracks of each luminaire and span the luminaire joint. When both fixtures are Leveled, screw in two #10 screws through the joining bracket plate (FIG. 4A). When both sides of the joining bracket are attached to both housings in the run with four #10 screws, tighten the Center Tension Screw on the joining bracket enough to hold luminaires snug to the mounting surface (FIG. 4B). Joining brackets are designed for a single-use. Contact the factory for the additional joining kits.

Step Seven: Continue to install and assemble row following steps 3-6.

Step Eight: Reassemble LED/Reflector tray in reverse fashion and ensure that there are no wires bound by the reflector as this will cause the lens to not fit correctly. For 2" wide product line only: When reinstalling the LED tray, hold it firm in the housing tracks, screw the first #8-18x1/4" with just a few revolutions, move to the middle, and to the last screw before screwing the first screw all the way in. Not following this step will cause the LED Tray to slide out of position and interfere with the end cap or the next fixture in a row. Apply the Light Shield Tape below the joining tab (FIG. 4B). Do not let the bottom of the tape to show below the edge of the housing.

Reinstall lens(es) when all tape pieces are applied.

Figure 4

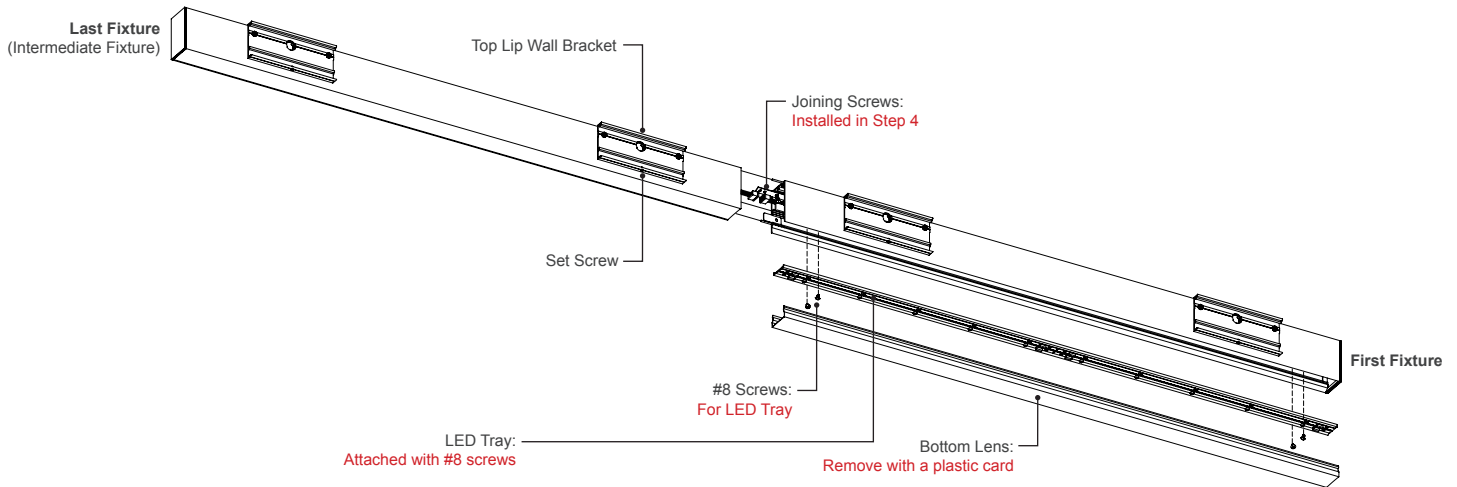

Figure 4A Shown In A Cross-Section For Clarity

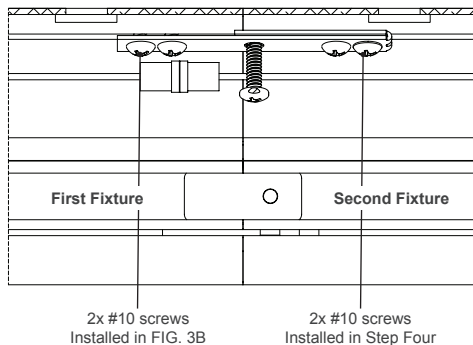
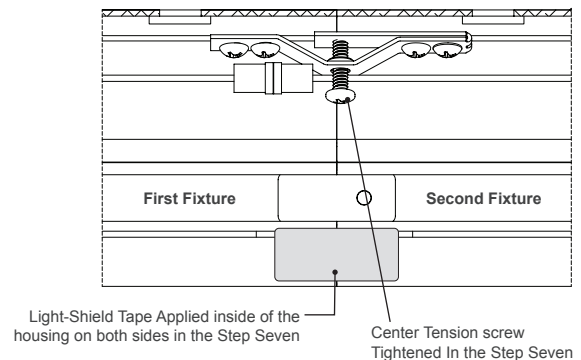

Figure 4B Shown In A Cross-Section For Clarity



SAVE THESE INSTALLATION INSTRUCTIONS

Fixture Row Layout: Single Unit 2' - 4' - 6' - 8' - 10' - 12'

2' FIXTURE

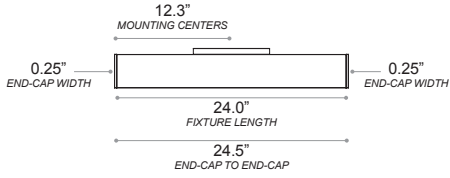

4' FIXTURE

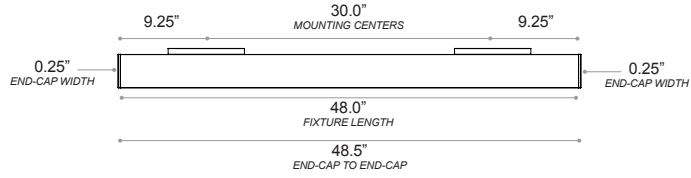

6' FIXTURE

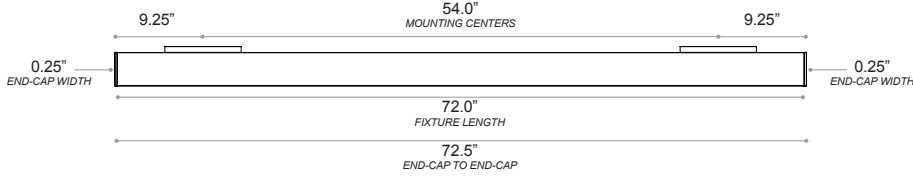

8' FIXTURE

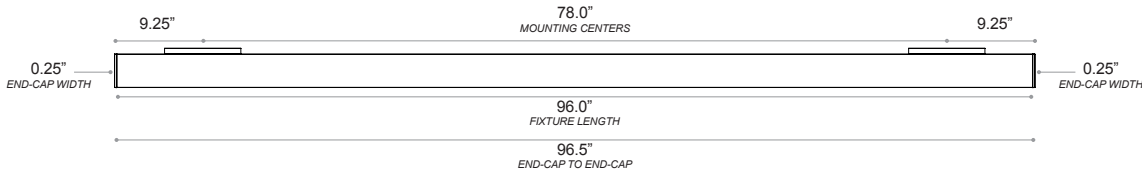

10' FIXTURE

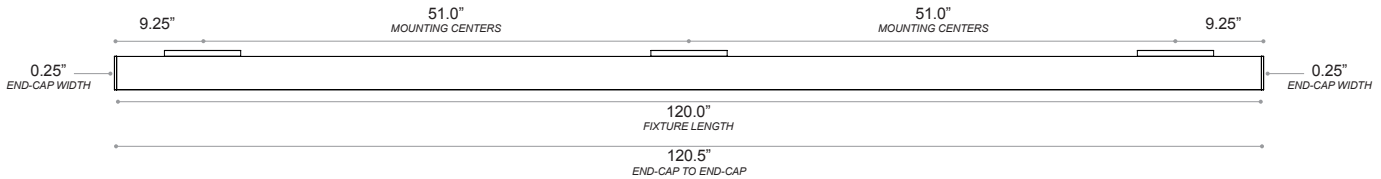

12' FIXTURE

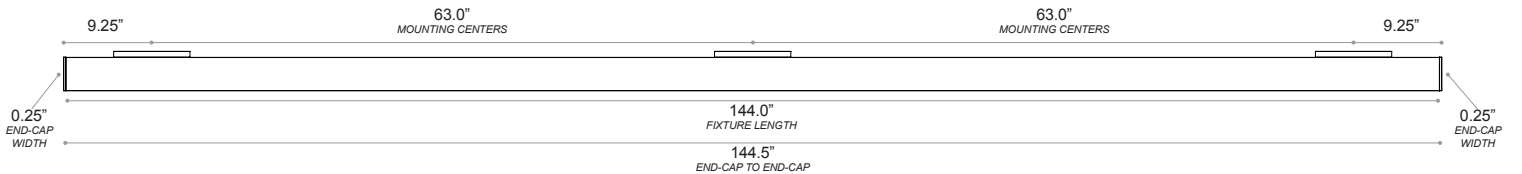

SAVE THESE INSTALLATION INSTRUCTIONS

Fixture Row Layout: Two Units 14' - 16'

14' FIXTURE

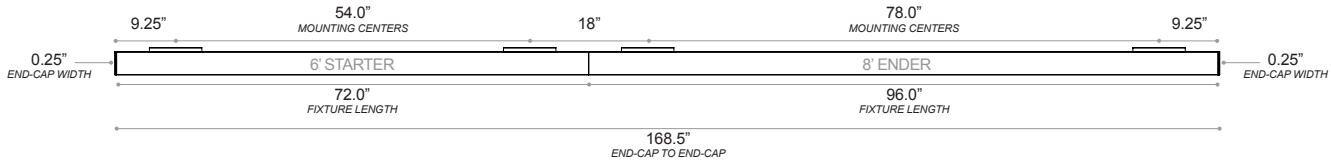

16' FIXTURE

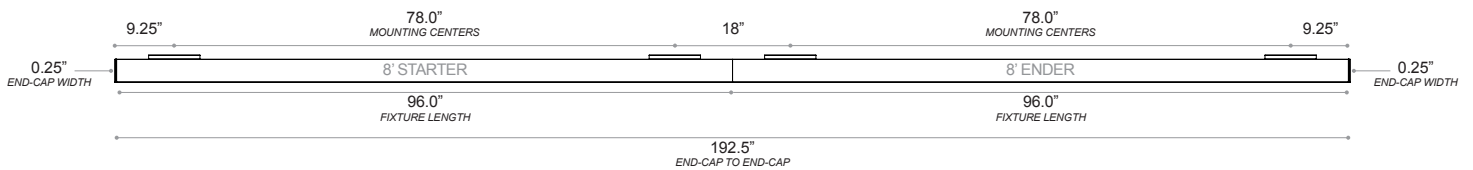

Fixture Row Layout: Three Units 18' - 20' - 22' - 24'

18' FIXTURE

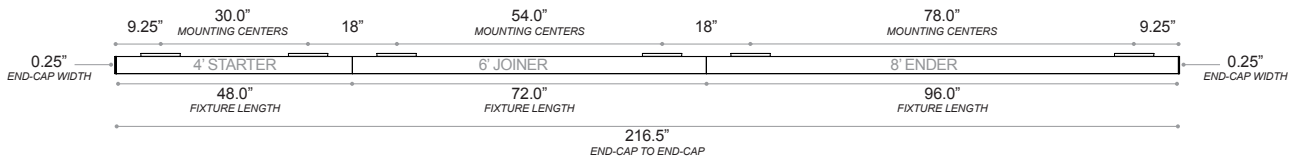

20' FIXTURE

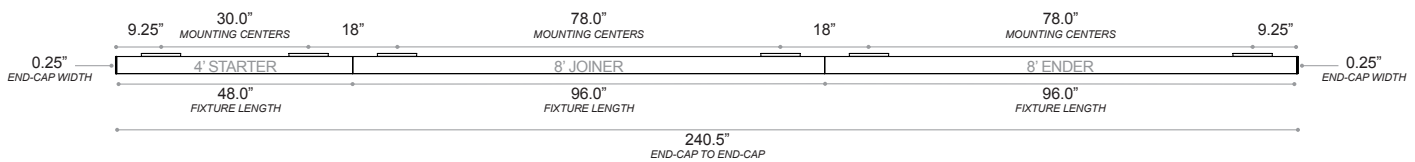

22' FIXTURE

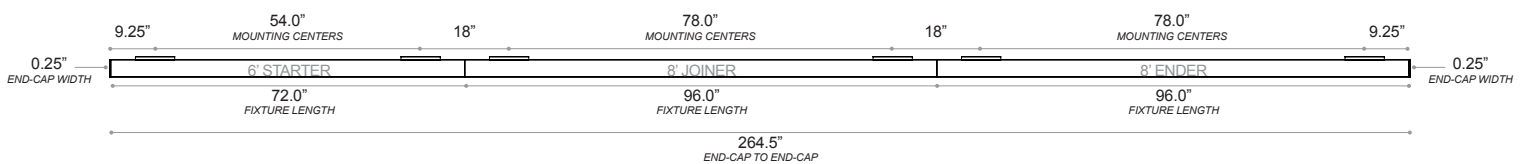

24' FIXTURE

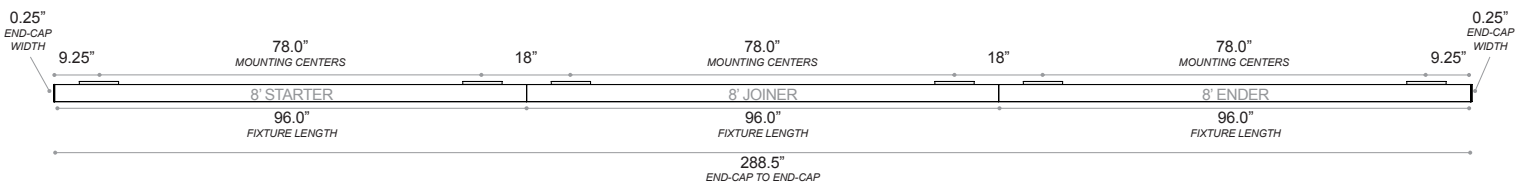

SAVE THESE INSTALLATION INSTRUCTIONS

Fixture Row Components

RUN LENGTH (FT)	FIXTURE LENGTHS									JOINER KITS
	STARTER	JOINER							ENDER	
	1	2	3	4	5	6	7	8	9	
14	6'	-	-	-	-	-	-	-	8'	1
16	8'	-	-	-	-	-	-	-	8'	1
18	4'	6'	-	-	-	-	-	-	8'	2
20	4'	8'	-	-	-	-	-	-	8'	2
22	6'	8'	-	-	-	-	-	-	8'	2
24	8'	8'	-	-	-	-	-	-	8'	2
26	4'	6'	8'	-	-	-	-	-	8'	3
28	4'	8'	8'	-	-	-	-	-	8'	3
30	6'	8'	8'	-	-	-	-	-	8'	3
32	8'	8'	8'	-	-	-	-	-	8'	3
34	4'	6'	8'	8'	-	-	-	-	8'	4
36	4'	8'	8'	8'	-	-	-	-	8'	4
38	6'	8'	8'	8'	-	-	-	-	8'	4
40	8'	8'	8'	8'	-	-	-	-	8'	4
42	4'	6'	8'	8'	8'	-	-	-	8'	5
44	4'	8'	8'	8'	8'	-	-	-	8'	5
46	6'	8'	8'	8'	8'	-	-	-	8'	5
48	8'	8'	8'	8'	8'	-	-	-	8'	5
50	4'	6'	8'	8'	8'	8'	-	-	8'	6
52	4'	8'	8'	8'	8'	8'	-	-	8'	6
54	6'	8'	8'	8'	8'	8'	-	-	8'	6
56	8'	8'	8'	8'	8'	8'	-	-	8'	6
58	4'	6'	8'	8'	8'	8'	8'	-	8'	7
60	4'	8'	8'	8'	8'	8'	8'	-	8'	7
62	6'	8'	8'	8'	8'	8'	8'	-	8'	7
64	8'	8'	8'	8'	8'	8'	8'	-	8'	7
66	4'	6'	8'	8'	8'	8'	8'	8'	8'	8
68	4'	8'	8'	8'	8'	8'	8'	8'	8'	8
70	6'	8'	8'	8'	8'	8'	8'	8'	8'	8
72	8'	8'	8'	8'	8'	8'	8'	8'	8'	8

	FIXTURE LENGTH	CENTER-TO-CENTER BRACKET SPACING
4'	48.0"	30.0"
6'	72.0"	54.0"
8'	96.0"	78.0"

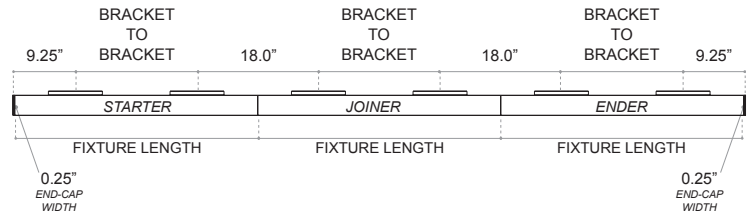

Note 1
2' fixtures use a single mounting bracket centered on the fixture

Note 2
10' & 12' fixtures have a third mounting bracket centered on the fixture

SAVE THESE INSTALLATION INSTRUCTIONS